

工序号：  
 机器型号 **IPN-ZBT-HO-2-RU**  
 机器名称 **开裤子缝中央供气烫台**  
 Mac.Name : **Central steam and suction pressing table for opening of trousers seams**  
 产量 productivity: 70 /hour  
 长度: 600 mm                      蒸气量: 12 kg/hour  
 宽度: 1950 mm                    压缩空气量: 25 l/min.  
 高度: 1200 mm                    抽真空量: 5 l/s

模具示意图

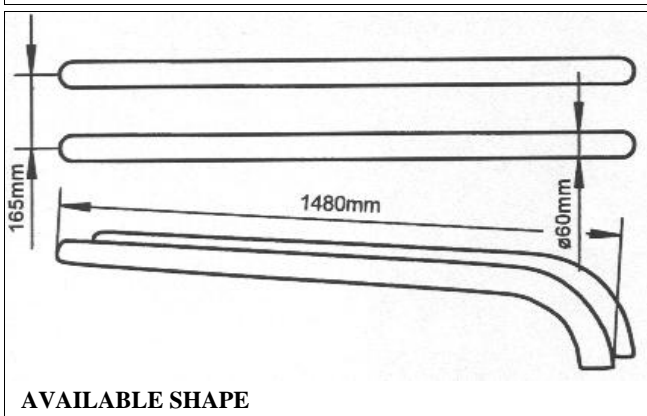

Serial equipments:

- tube shape bucks for seams opening
- special concave iron
- natural stretching chain for fixing without over-stretching the trousers
- for connection on the central steam and vacuum supply
- with pneumatic vacuum valve (fix vacuum)
- steam heated
- adjustable in height
- steam gallow
- connection load: 230/50Hz

基本配置：

- 圆形劈缝模具
- 特殊凹型劈缝熨斗
- 模具底下的链条使裤子自然垂直，并可固定劈缝熨斗位置
- 连接中央蒸气和抽真空
- 使用气动真空阀（定位抽真空）
- 蒸汽加热
- 高度可调
- 蒸汽支架
- 连接数值：230/50Hz

550114	stainless steel iron Type: LU 5-hole/hollow sole with quantity regulation	LU 5孔弧型专用劈缝熨斗、附气量调节	1
273003	connecting material, 1/3000, insulated 3/8" x 3000mm	连接材料1条3000mm, 3/8"	1
271024	coverings of 1st class soft for trouser seams 2 bucks	2个劈裤缝模具的包布	1
155992	packing pressing table IPN-ZBT	包装	1